

WSA

Water cooled chillers

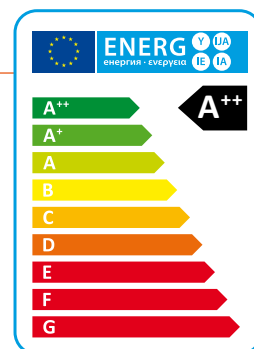

WSA water chillers have been designed for small and medium residential and commercial applications.

They are designed to operate with water outlet temperatures of 7°C, commonly used in combinations with fan coils or/ and air handling units.

The units are designed for indoor installation and have low noise levels in operation.

Due to the compact dimensions, the versatility in installation and a wide range of accessories, the WSA series are ideal for most applications.

VERSIONS

- STD** Cooling only version.
- HP** Reversible version.
- EV** Condenserless version.

ACCESSORIES

- DSSE** Soft starter elettronico.
- INSE** Serial interface card RS485.
- KAVG** Rubber anti-vibration mountings.
- KAVM** Spring anti-vibration mountings.
- LS00** Low noise version.
- MAML** Refrigerant circuit pressure gauges.
- PCRL** Remote control panel.
- RP00** Partial heat recovery.
- V2M0** Source 4÷20 mA modulating valve.
- VPSF** Pressostatic valve kit (only cooling version).

WSA - WSA/HP Models		06	08	10	14	16	21	26	31	36	41
Energy Class in low temp. - Accord. to EU reg. 811/2013		A++	A++	A++	A++	A++	A++	A++	A++	A++	A++
Cooling capacity (EN14511) ⁽¹⁾	kW	5,9	7,5	9,0	14,9	17,4	22,0	30,3	34,3	38,2	45,0
Total input power (EN14511) ⁽¹⁾	kW	1,5	1,8	2,2	3,6	4,2	5,1	6,9	7,8	8,7	10,2
EER (EN14511) ⁽¹⁾	w/w	3,9	4,2	4,1	4,1	4,1	4,3	4,4	4,4	4,4	4,4
Cooling capacity (EN14511) ⁽²⁾	kW	8,1	10,2	12,2	20,4	23,5	29,5	40,3	45,5	50,7	60,3
Total input power (EN14511) ⁽²⁾	kW	1,4	1,8	2,2	3,5	4,3	5,4	7,1	8,0	9,1	10,4
EER (EN14511) ⁽²⁾	w/w	5,8	5,7	5,5	5,8	5,5	5,5	5,7	5,7	5,6	5,8
Heating capacity (EN14511) ⁽³⁾	kW	7,0	8,8	10,6	17,2	20,3	25,3	34,3	42,6	47,9	52,7
Total input power (EN14511) ⁽³⁾	kW	1,5	1,8	2,2	3,6	4,2	5,1	6,9	7,9	8,8	10,3
COP (EN14511) ⁽³⁾	w/w	4,7	4,9	4,8	4,8	4,8	5,0	5,0	5,4	5,4	5,1
Heating capacity (EN14511) ⁽⁴⁾	kW	6,7	8,4	10,2	16,5	19,5	24,4	32,7	40,7	45,8	50,5
Total input power (EN14511) ⁽⁴⁾	kW	1,9	2,3	2,8	4,5	5,2	6,3	8,6	9,9	10,9	12,5
COP (EN14511) ⁽⁴⁾	w/w	3,5	3,6	3,6	3,7	3,8	3,9	3,8	4,1	4,2	4,0
Power supply	V/Ph/Hz	230/1/50	230/1/50	230/1/50	400/3+N/50	400/3+N/50	400/3+N/50	400/3+N/50	400/3+N/50	400/3+N/50	400/3+N/50
Peak current	A	60	67	98	64	75	95	118	118	140	174
Maximum input current	A	12,8	17,1	22,0	11,3	15,0	16,0	22,0	25,0	31,0	34,0
Compressors / Circuits	n°	1/1	1/1	1/1	1/1	1/1	1/1	1/1	1/1	1/1	1/1
Sound power ⁽⁵⁾	dB(A)	51	52	52	54	54	60	60	62	64	64
Sound pressure ⁽⁶⁾	dB(A)	43	44	44	46	46	52	52	54	56	56

Performance refer to the following conditions:

- (1)Cooling: Evaporator water temperature in/out 12/7°C condenser water temperature in/out 30/35°C. Without pressostatic valve.
- (2)Cooling: Evaporator water temperature in/out 23/18°C condenser water temperature in/out 30/35°C. Without pressostatic valve.
- (3)Heating: condenser water temperature in/out 30/35°C; evaporator water temperature in/out 10/7°C.

- (4)Heating: condenser water temperature in/out 40/45°C; evaporator water temperature in/out 10/7°C.
- (5)Sound power level in accordance with ISO 9614 (LS versions).
- (6)Sound pressure level at 1 mt from the unit in free field conditions direction factor Q = 2 in accordance with ISO 9614 (LS versions).

WSA/EV Models		06	08	10	14	16	21	26	31	36	41
Cooling capacity ⁽⁷⁾	kW	5,1	6,5	7,9	13,1	15,3	19,5	26,6	30,0	33,7	39,8
Total input power ⁽⁷⁾	kW	1,9	2,4	2,9	4,6	5,3	6,4	8,9	10,2	11,1	12,7
Water flow ⁽⁷⁾	m³/h	0,9	1,1	1,4	2,2	2,6	3,3	4,6	5,1	5,8	6,8
Peak current	A	60	67	98	64	75	95	118	118	140	174
Max input current	A	12,8	17,1	22,0	11,3	15,0	16,0	22,0	25,0	31,0	34,0
Power supply	V/Ph/Hz	230/1/50	230/1/50	230/1/50	400/3+N/50	400/3+N/50	400/3+N/50	400/3+N/50	400/3+N/50	400/3+N/50	400/3+N/50
Compressors / Circuits	n°	1/1	1/1	1/1	1/1	1/1	1/1	1/1	1/1	1/1	1/1
Sound power level ⁽⁵⁾	dB(A)	51	52	52	54	54	60	60	62	64	64
Sound pressure level ⁽⁶⁾	dB(A)	43	44	44	46	46	52	52	54	56	56

Performance refer to the following conditions:

- (5)Sound power level in accordance with ISO 9614. (LS versions).
- (6)Sound pressure level at 1 mt from the unit in free field conditions direction factor Q = 2 in accordance with ISO 9614 (LS versions).
- (7) For EV version: condensing temperature 50 °C, water temperature in/out 12/7 °C.

FRAME

All WSA units are made from hot-galvanised sheet steel, painted with polyurethane powder enamel and stoved at 180°C to provide maximum protection against corrosion. The frame is self-supporting with removable panels. All screws and rivets used are made from stainless steel. The standard colour of the units is RAL 9018.

REFRIGERANT CIRCUIT

The refrigerant utilised is R410A. The refrigerant circuit is assembled using internationally recognised brand name components with all brazing and welding being performed in accordance with ISO 97/23. The refrigerant circuit includes: sight glass, filter drier, reversing valve (for reversible version only), one way valve (for reversible version only), liquid receiver (for reversible version only), Schraeder valves for maintenance and control and pressure safety device (for compliance with PED regulations).

COMPRESSORS

For models 06,08,10 rotary type compressors are used. For all other models the compressors are of the scroll type. All compressors are fitted with a crankcase heater and each compressor has a klixon embedded in the motor winding for thermal overload protection. They are mounted within the casing. The crankcase heater is always energised when the compressor is in stand-by. Access to the compressors is by removal of a front panel and maintenance of the compressors is possible whilst the unit is operating.

CONDENSERS AND EVAPORATORS

The evaporators and the condensers are braze welded, plate type heat exchangers, manufactured from AISI 316 stainless steel. Utilisation of this type of exchanger results in a massive reduction of the refrigerant charge of the unit compared to the traditional shell-in-tube type. A further advantage is a reduction in the overall dimensions of the unit. The evaporators are factory insulated with flexible close cell material and can be fitted with an antifreeze heater (accessory). In the reversible version, the condensers are factory insulated with flexible close cell material and can be equipped with an anti-freeze heater (accessory). Each evaporator

is fitted with a temperature sensor on the discharge water side for antifreeze protection.

MICROPROCESSOR

All WSA units are supplied with microprocessor controls loaded with ACTIVE auto-adaptive strategy. The microprocessor controls the following functions: control of the water temperature, antifreeze protection, compressor timing, compressor automatic starting sequence, alarm reset, volt free contact for remote general alarm, alarms and operation LED's. If required (available as an option), the microprocessor can be configured in order for it to connect to a site BMS system thus enabling remote control and management. The Hidros technical department can discuss and evaluate, in conjunction with the customer, solutions using MODBUS protocols. The autoadaptive control system ACTIVE is an advanced strategy that continuously monitors the temperature of the inlet and outlet water thereby determining the variation of the building thermal load. By then adjusting the outlet water temperature set point the compressor start/stop cycle can be accurately controlled thus optimizing the unit efficiency and maximizing the operational life of the units component's. Use of ACTIVE auto-adaptive Control enables the minimum water content to be reduced from the traditional 12-15 l/kw to 5 l/kw. A further benefit of the reduced water requirement is that WSA units can be used in installations without a buffer tank thereby reducing the space requirements, thermal losses and costs.

ELECTRIC ENCLOSURE

The enclosure is manufactured in order to comply with the requirements of the electromagnetic compatibility standards CEE 73/23 and 89/336. Access to the enclosure is achieved by removing the front panel of the unit. The following components are supplied as standard on all units: main switch, thermal overloads (protection of pumps and fans), compressor fuses, control circuit automatic breakers, compressor contactors, fan contactors and pump contactors. The terminal board has volt free contacts for remote ON-OFF, Summer / winter change over (reversible versions only) and general

alarm. For all three phase units, a sequence relay that disables the power supply in the event that the phase sequence is incorrect (scroll compressors can be damaged if they rotate in the wrong direction), is fitted as standard.

CONTROL AND PROTECTION DEVICES

All units are supplied with the following control and protection devices: Return water temperature sensor installed on the return water line from the building (12°C), antifreeze protection sensor installed on the outlet water temperature (7°C), high pressure switch with manual reset, low pressure switch with automatic reset, high pressure safety valve, compressor thermal overload protection, fans thermal overload protection and flow switch.

CONDENSERLESS VERSIONS EV

This version includes a microprocessor control to manage both the compressor timings and alarms. It is designed to operate with refrigerant R410A but is supplied with a holding charge of nitrogen.

REVERSIBLE VERSIONS HP

The reversible versions are provided with a 4 way reversing valve and are designed to produce hot water up to a temperature of 50°C. They are always supplied with a liquid receiver and a second thermostatic valve in order to optimize the efficiency of the refrigerant cycle in heating and in cooling.

WSA - WSA/EV - WSA/HP Versions	Code	06	08	10	14	16	21	26	31	36	41
Main switch	-	-	-	-	●	●	●	●	●	●	●
Flow switch	-	●	●	●	●	●	●	●	●	●	●
Microprocessor control	-	●	●	●	●	●	●	●	●	●	●
LS low noise basic version	LS00	○	○	○	○	○	○	○	○	○	○
Partial heat recovery	RP00	-	-	-	○	○	○	○	○	○	○
Spring anti-vibration mountings	KAVM	○	○	○	○	○	○	○	○	○	○
Rubber anti-vibration mountings	KAVG	○	○	○	○	○	○	○	○	○	○
Refrigerant circuit pressure gauges	MAML	○	○	○	○	○	○	○	○	○	○
Pressostatic valve kit (only cooling version)	VPSF	○	○	○	○	○	○	○	○	○	○
V2M0: Source 4÷20 mA modulating valve	V2M0	○	○	○	○	○	○	○	○	○	○
Electronic soft starter	DSSE	○	○	○	○	○	○	○	○	○	○
Remote control panel	PCRL	○	○	○	○	○	○	○	○	○	○
Serial interface card RS485	INSE	○	○	○	○	○	○	○	○	○	○

● Standard, ○ Optional, – Not available.

OPERATION LIMITS

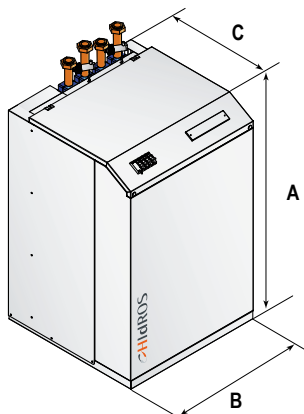
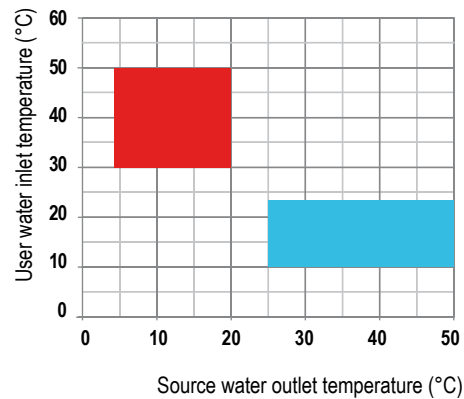
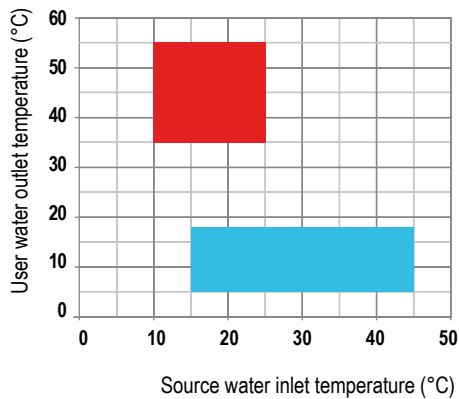

WSA 06 ÷ 21

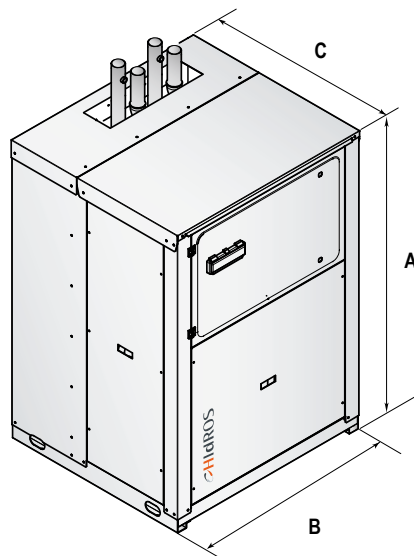

WSA 26 ÷ 41

Mod.	A (mm)	B (mm)	C (mm)	Kg
06	900	600	600	130
08	900	600	600	135
10	900	600	600	138
14	1255	600	600	140
16	1255	600	600	170
21	1255	600	600	175
26	1270	850	765	180
31	1270	850	765	340
36	1270	850	765	350
41	1270	850	765	360