

WDA

Water cooled chillers

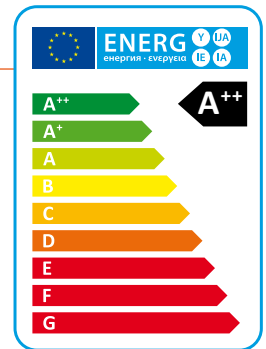

WDA water chillers are efficient, low-noise products designed for medium to large applications.

They are suitable for generating chilled water at temperatures in the region of 7°C, commonly used in applications with fan coils and/or air handling units.

The use of tandem scroll compressors results in high efficiencies (especially at part loads) and low noise levels, making them suitable for use in many applications.

Differing versions and a wide range of accessories, enable the optimal solution to be selected.

VERSIONS

- STD** Cooling only version.
- HP** Reversible version.
- EV** Condenserless version.

ACCESSORIES

- S1NT** Hydraulic kit only pump source circuit.
- DSSE** Electronic soft starter.
- KAVG** Rubber anti-vibration mountings.
- KAVM** Spring anti-vibration mountings.
- LS01** Low noise version.
- MAML** Refrigerant circuit pressure gauges.
- PCRL** Remote control panel.
- RP00** Partial heat recovery.
- V2M0** Source 4÷20 mA modulating valve.
- VPSF** Pressostatic valve kit for cooling versions.
- VSLI** Liquid line solenoid valve.

WDA - WDA/HP Models		039	045	050	060	070	080	090	110	120	130
Energy Class in low temp. - Accord. to EU reg. 811/2013		A++	A++	A++	A++	A++	A++	A++	A++	A++	A++
Cooling capacity (EN14511) ⁽¹⁾	kW	43,7	49,9	59,3	67,2	75,0	88,5	100,8	112,0	126,5	141,1
Total input power (EN14511) ⁽¹⁾	kW	10,5	12,1	15,1	16,7	17,7	20,9	23,9	26,9	30,5	34,0
EER (EN14511) ⁽¹⁾	w/w	4,2	4,1	3,9	4,0	4,2	4,2	4,2	4,2	4,1	4,2
Cooling capacity (EN14511) ⁽²⁾	kW	58,9	67,4	79,6	90,6	101,1	118,3	135,7	151,6	171,2	189,8
Total input power (EN14511) ⁽²⁾	kW	11,1	12,3	15,7	17,5	18,7	21,3	24,7	28,2	31,8	35,3
EER (EN14511) ⁽²⁾	w/w	5,3	5,5	5,1	5,2	5,4	5,6	5,5	5,4	5,4	5,4
Heating capacity (EN14511) ⁽³⁾	kW	48,8	55,9	65,8	74,0	83,8	98,5	118,3	132,8	149,8	166,6
Total input power (EN14511) ⁽³⁾	kW	10,6	11,9	13,7	15,6	17,1	20,4	24,1	27,1	30,7	34,1
COP (EN14511) ⁽³⁾	w/w	4,6	4,7	4,8	4,7	4,9	4,8	4,9	4,9	4,9	4,9
Heating capacity (EN14511) ⁽⁴⁾	kW	46,9	53,7	63,1	70,9	80,1	94,9	113,7	127,4	143,8	160,5
Total input power (EN14511) ⁽⁴⁾	kW	13,0	14,7	17,2	19,4	21,2	24,8	29,3	32,9	37,3	41,5
COP (EN14511) ⁽⁴⁾	w/w	3,6	3,7	3,7	3,7	3,8	3,8	3,9	3,9	3,9	3,9
Power supply	V/Ph/Hz	400/3/50	400/3/50	400/3/50	400/3/50	400/3/50	400/3/50	400/3/50	400/3/50	400/3/50	400/3/50
Peak current	A	111,0	132,0	140,0	162,0	171,0	208,0	259,0	265,0	312,0	320,5
Maximum input current	A	32,0	42,0	44,0	53,0	62,0	68,0	74,0	80,0	88,5	97,0
Compressors / Circuits	n°	2/1	2/1	2/1	2/1	2/1	2/1	2/1	2/1	2/1	2/1
Sound power ⁽⁵⁾	dB(A)	74	74	75	76	76	77	77	78	78	79
Sound pressure ⁽⁶⁾	dB(A)	46	46	47	48	48	49	49	50	50	51

Performance refer to the following conditions:

- (1)Cooling: Evaporator water temperature in/out 12/7°C condenser water temperature in/out 30/35°C. Without pressostatic valve.
- (2)Cooling: Evaporator water temperature in/out 23/18°C condenser water temperature in/out 30/35°C. Without pressostatic valve.
- (3)Heating: condenser water temperature in/out 30/35°C; evaporator water temperature in/out 10/7°C.

(4)Heating: condenser water temperature in/out 40/45°C; evaporator water temperature in/out 10/7°C.

(5)Sound power level in accordance with ISO 9614 (LS-Version).

(6)Sound pressure level at 10 mt from the unit in free field conditions direction factor Q = 2 in accordance with ISO 9614 (LS-Version).

OPERATION LIMITS

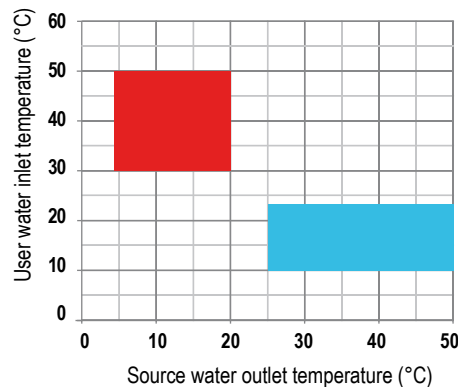
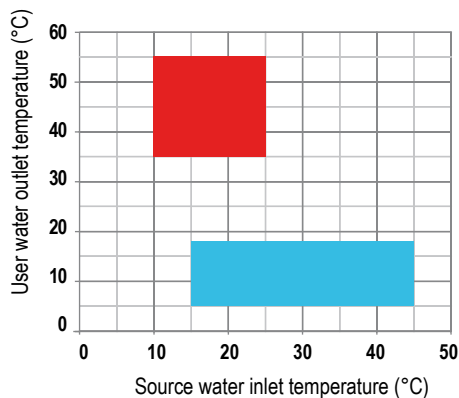

WDA - WDA/HP Models		152	162	190	210	240	260	300	320	380	430	500
Energy Class in low temp. - Accord. to EU reg. 811/2013		A++	A++	A++	A++	A++	A++	A++	A++	A++	A++	A++
Cooling capacity (EN14511) ⁽¹⁾	kW	162,4	182,5	201,6	223,9	257,6	285,7	323,5	365,2	421,1	474,2	535,1
Total input power (EN14511) ⁽¹⁾	kW	38,7	43,4	47,8	53,8	60,9	68,0	77,4	86,7	101,9	112,2	126,3
EER (EN14511) ⁽¹⁾	w/w	4,2	4,2	4,2	4,2	4,2	4,2	4,2	4,2	4,1	4,2	4,2
Cooling capacity (EN14511) ⁽²⁾	kW	218,5	249,3	273,5	305,2	350,7	387,0	437,3	496,1	585,4	658,4	742,9
Total input power (EN14511) ⁽²⁾	kW	40,4	45,6	49,5	56,5	64,0	71,1	81,2	91,5	106,5	117,8	133,2
EER (EN14511) ⁽²⁾	w/w	5,4	5,5	5,5	5,4	5,5	5,4	5,4	5,4	5,5	5,6	5,6
Heating capacity (EN14511) ⁽³⁾	kW	190,9	216,5	237,4	266,4	301,4	325,9	367,7	422,4	501,0	567,1	637,2
Total input power (EN14511) ⁽³⁾	kW	38,9	43,6	48,2	54,2	61,0	67,9	77,0	86,6	101,5	115,2	128,2
COP (EN14511) ⁽³⁾	w/w	4,9	5,0	4,9	4,9	4,9	4,8	4,8	4,9	4,9	4,9	5,0
Heating capacity (EN14511) ⁽⁴⁾	kW	186,9	206,6	227,0	254,4	287,7	312,0	352,7	403,8	477,7	540,7	607,4
Total input power (EN14511) ⁽⁴⁾	kW	47,4	53,0	58,6	65,8	74,3	82,7	93,9	105,6	121,2	137,8	153,4
COP (EN14511) ⁽⁴⁾	w/w	3,9	3,9	3,9	3,9	3,9	3,8	3,8	3,8	3,9	3,9	4,0
Power supply	V/Phz	400/3/50	400/3/50	400/3/50	400/3/50	400/3/50	400/3/50	400/3/50	400/3/50	400/3/50	400/3/50	400/3/50
Peak current	A	358,5	375,4	333,0	345,0	400,5	417,5	472,4	506,2	514,5	586,3	637,0
Maximum input current	A	113,9	130,8	148,0	160,0	177,0	194,0	227,8	261,6	291,0	341,7	392,4
Compressors / Circuits	n°	2/1	2/1	4/2	4/2	4/2	4/2	4/2	4/2	6/2	6/2	6/2
Sound power ⁽⁵⁾	dB(A)	79	79	80	82	82	82	84	84	92	92	92
Sound pressure ⁽⁶⁾	dB(A)	51	51	52	54	54	54	56	56	64	64	64

Performance refer to the following conditions:

(1)Cooling: Evaporator water temperature in/out 12/7°C condenser water temperature in/out 30/35°C.

Without pressostatic valve.

(2)Cooling: Evaporator water temperature in/out 23/18°C condenser water temperature in/out 30/35°C.

Without pressostatic valve.

(3)Heating: condenser water temperature in/out 30/35°C; evaporator water temperature in/out 10/7°C.

(4)Heating: condenser water temperature in/out 40/45°C; evaporator water temperature in/out 10/7°C.

(5)Sound power level in accordance with ISO 9614 (LS-Version).

(6)Sound pressure level at 10 mt from the unit in free field conditions direction factor Q = 2 in accordance with ISO 9614 (LS-Version).

OPERATION LIMITS

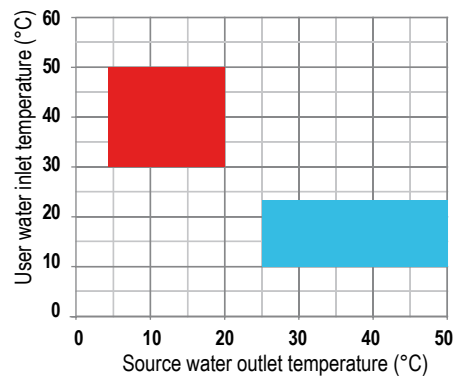
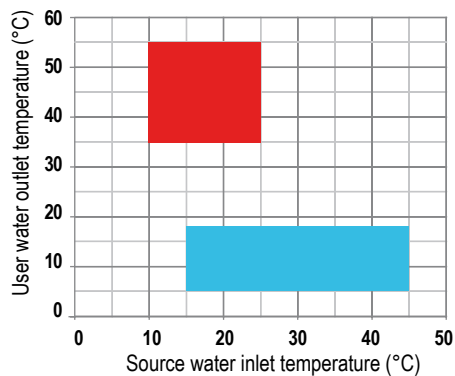

WDA/EV Models		039	045	050	060	070	080	090	110	120	130	152
Cooling capacity ⁽⁵⁾	kW	38,8	44,3	52,4	59,3	66,0	78,9	90,4	99,7	112,8	125,8	145,0
Total input power ⁽⁵⁾	kW	13,2	15,3	19,4	21,1	22,4	25,9	29,6	33,4	37,7	42,2	48,0
Water flow ⁽⁵⁾	m ³ /h	6,7	7,6	9,0	10,2	11,3	13,5	15,5	17,1	19,4	21,6	24,9
Peak current	A	111,0	132,0	140,0	162,0	171,0	208,0	259,0	265,0	312,0	320,5	358,5
Max input current	A	32,0	42,0	44,0	53,0	62,0	68,0	74,0	80,0	88,5	97,0	113,9
Power supply	V/Ph/Hz	400/3/50	400/3/50	400/3/50	400/3/50	400/3/50	400/3/50	400/3/50	400/3/50	400/3/50	400/3/50	400/3/50
Compressors / Circuits	n°	2/1	2/1	2/1	2/1	2/1	2/1	2/1	2/1	2/1	2/1	2/1
Sound power level ⁽³⁾	dB(A)	74	74	75	76	76	77	77	78	78	79	79
Sound pressure level ⁽⁴⁾	dB(A)	46	46	47	48	48	49	49	50	50	51	51

WDA/EV Models		162	190	210	240	260	300	320	380	430	500
Cooling capacity ⁽⁵⁾	kW	162,6	178,3	197,8	221,4	245,8	277,5	314,0	363,1	416,8	466,8
Total input power ⁽⁵⁾	kW	53,9	59,2	66,5	76,3	85,1	96,9	108,6	126,5	143,8	161,5
Water flow ⁽⁵⁾	m ³ /h	27,9	30,6	33,9	38,0	42,2	47,6	53,9	62,3	71,5	80,1
Peak current	A	375,4	333,0	345,0	400,5	417,5	472,4	506,2	514,5	586,3	637,0
Max input current	A	130,8	148,0	160,0	177,0	194,0	227,8	261,6	291,0	341,7	392,4
Power supply	V/Ph/Hz	400/3/50	400/3/50	400/3/50	400/3/50	400/3/50	400/3/50	400/3/50	400/3/50	400/3/50	400/3/50
Compressors / Circuits	n°	2/1	4/2	4/2	4/2	4/2	4/2	4/2	6/2	6/2	6/2
Sound power level ⁽³⁾	dB(A)	79	80	82	82	82	84	84	92	92	92
Sound pressure level ⁽⁴⁾	dB(A)	51	52	54	54	54	56	56	64	64	64

Performance refer to the following conditions:

(5)For EV version: condensing temperature 50 °C, water temperature in/out 12/7 °C.

(3)Sound power level in accordance with ISO 9614. (LS verions).

(4)Sound pressure level at 10 mt from the unit in free field conditions direction factor Q = 2 in accordance with ISO 9614 (LS versions)

FRAME

All WDA units are made from hot-galvanised sheet steel, painted with polyurethane powder enamel and stoved at 180°C to provide maximum protection against corrosion. The frame is self-supporting with removable panels. All screws and rivets used are made from stainless steel. The standard colour of the units is RAL 9018.

REFRIGERANT CIRCUIT

The refrigerant utilised is R410A. The refrigerant circuit is assembled using internationally recognised brand name components with all brazing and welding being performed in accordance with ISO 97/23. Each refrigerant circuit is totally independent from the other. Failure of one circuit does not influence the other circuit. The refrigerant circuit includes: sight glass, filter drier, reversing valve (for reversible version only), one way valve (for reversible version only), liquid receiver (for reversible version only), Schraeder valves for maintenance and control and pressure safety device (for compliance with PED regulations). Also available is an electronic expansion valve with electronic control which optimises the efficiency in part load conditions (option).

COMPRESSORS

The compressors utilised are scroll type. All compressors are fitted with a crankcase heater and each compressor has a klixon embedded in the motor winding for thermal overload protection. The crankcase heater is always energised when the compressor is in stand-by. Access to the compressors is through the front and side panels. The compressors used are all in tandem configuration. This results in much higher efficiencies at part loads compared to units with independent refrigerant circuits.

CONDENSERS

The condensers are braze welded, plate type heat exchangers, manufactured from AISI 316 stainless steel. Utilisation of this type of exchanger results in a massive reduction of the refrigerant charge of the unit compared to the traditional shell-in-tube type. A further advantage is a reduction in the overall dimensions of the unit and an increase in efficiency of the refrigerant cycle in partial loads.. From size 039 to size 162

they have a single water side circuit, from size 144 upwards they are double circuit "cross flow" type.

EVAPORATORS

The evaporators are braze welded, plate type heat exchangers, manufactured from AISI 316 stainless steel. From size 039 to size 162 they have a single water side circuit, from size 190 upwards they are double circuit "cross flow" type.

All units are supplied with a sub-cooler to enhance the performance of the refrigerant cycle. The evaporators are factory insulated with flexible close cell material and are supplied with a temperature sensor as antifreeze protection.

MICROPROCESSORS

All WDA units are supplied as standard with microprocessor controls. The microprocessor controls the following functions: control of the water temperature, antifreeze protection, compressor timing, compressor automatic starting sequence, alarm reset, volt free contact for remote general alarm, alarms and operation LED's. If required (available as an option), the microprocessor can be configured in order for it to connect to a site BMS system thus enabling remote control and management. The Hidros technical department can discuss and evaluate, in conjunction with the customer, solutions using MODBUS protocols.

ELECTRICS ENCLOSURE

The enclosure is manufactured in order to comply with the requirements of the electromagnetic compatibility standards CEE 73/23 and 89/336. Access to the enclosure is achieved by removing the front panel of the unit. The following components are supplied as standard on all units: main switch, thermal overloads (protection of pumps and fans), compressor fuses, control circuit automatic breakers, compressor contactors, fan contactors and pump contactors. The terminal board has volt free contacts for remote ON-OFF, Summer/Winter change over (reversible versions only) and general alarm. For all three phase units, a sequence relay that disables the power supply in the event that the phase sequence is incorrect (scroll compressors can be damaged if they rotate in the wrong direction), is fitted as standard.

CONTROL AND PROTECTION DEVICES

All units are supplied with the following control and protection devices: Return water temperature sensor installed on the return water line from the building (12°C), antifreeze protection sensor installed on the outlet water temperature (7°C), high pressure switch with manual reset, low pressure switch with automatic reset, high pressure safety valve, compressor thermal overload protection, fans thermal overload protection and flow switch.

CONDENSERLESS VERSIONS EV

This version includes a microprocessor control to manage both the compressor timings and alarms. It is designed to operate with refrigerant R410a but is supplied with a holding charge of nitrogen.

REVERSIBLE VERSIONS HP

The reversible versions are provided with a 4 way reversing valve and are designed to produce hot water up to a temperature of 50°C. They are always supplied with a liquid receiver and a second thermostatic valve in order to optimize the efficiency of the refrigerant cycle in heating and in cooling. The microprocessor controls defrost automatically (when operating in low ambient conditions) and also the summer/winter change over.

PARTIAL HEAT RECOVERY RP

This version is supplied with an auxiliary heat exchanger fitted in series with the unit condenser thereby enabling it to produce hot water when the unit is operating in cooling mode.

WDA - WDA/HP - WDA/EV Versions	Code	039-080	090-162	190-320	380-500
Main switch	-	●	●	●	●
Flow switch	-	●	●	●	●
LS low noise versions	LS01	○	○	○	○
Hydraulic kit S1NT with only pump source circuit	S1NT	○	○	○	○
Partial heat recovery	RP00	○	○	○	○
Rubber anti-vibration mountings	KAVG	○	○	○	○
Spring anti-vibration mountings	KAVM	○	○	○	○
Electronic soft starter	DSSE	○	○	○	○
Refrigerant circuit pressure gauges	MAML	○	○	○	○
Liquid line solenoid valve	VSLI	○	○	○	○
Pressostatic valve kit for cooling versions	VPSF	○	○	○	○
Remote control panel	PCRL	○	○	○	○
Serial interface card RS485	INSE	○	○	○	○
Source 4÷20 mA modulating valve	V2M0	○	○	○	○

● Standard, ○ Optional, – Not available.

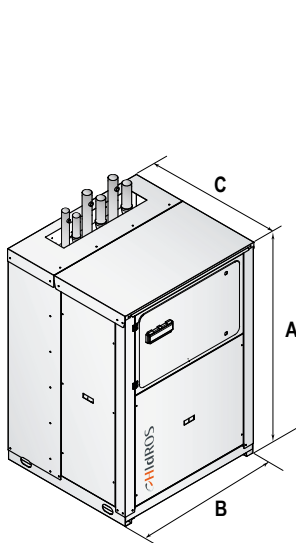

WDA 039 ÷ 162

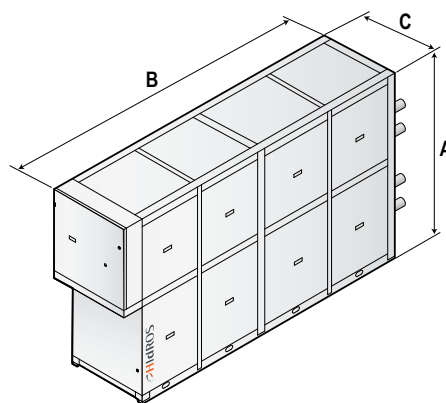

WDA 190 ÷ 320

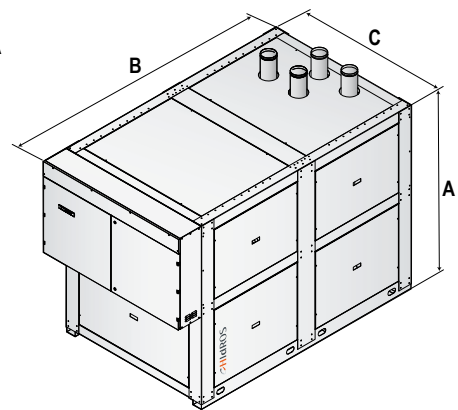

WDA 380 ÷ 500

Mod.	A (mm)	B (mm)	C (mm)	Kg
039	1566	1101	1005	430
045	1566	1101	1005	440
050	1566	1101	1005	460
060	1566	1101	1005	470
070	1566	1101	1005	480
080	1566	1101	1005	490
090	1986	1101	1255	580
110	1986	1101	1255	600
120	1986	1101	1255	630
130	1986	1101	1255	650
152	1986	1101	1255	730
162	1986	1101	1255	760

Mod.	A (mm)	B (mm)	C (mm)	Kg
190	1900	2170	800	1170
210	1900	2170	800	1210
240	1900	2170	800	1270
260	1900	2170	800	1320
300	1900	2170	800	1390
320	1900	2170	800	1430
380	2100	2750	1600	2550
430	2100	2750	1600	2690
500	2100	2750	1600	2750