

FL - FLD - FLZ

Industrial dehumidifiers



FL



FLD



FLZ (Outdoor unit)

FL dehumidifiers series are high-performances units especially designed for industrial or commercial purposes where humidity level should be controlled or water vapour condensation should be prevented. These units are particularly indicated for archives, ironing rooms, bookstores, cheese factories, underground rooms, cellars and industrial sites where high humidity level is present. This series comprises 3 basic models which cover a capacity range from 564 to 940 l/24h. FL units are designed for easy maintenance and service, each part being readily accessible and, when required, easily replaceable thus reducing service and maintenance costs.

VERSIONS

FLZ **Version with temperature control:** These versions are supplied with a remote condenser and are used in those applications where it is necessary the simultaneous control of temperature and humidity: Dehumidification mode: the internal condenser is activated; the unit dehumidifies and heats up the room temperature; Cooling mode: the remote condenser is activated; the unit dehumidifies and cools down the room temperature.

VERSIONS

- S** **Hot gas defrost version:** Beside the components of the standard version, the unit is supplied with a solenoid valves set for the hot gas injection used to defrost the evaporator in case of severe working conditions. The hot gas injection allows a faster defrost time and this permits to use this unit in areas with lower temperatures (down to 1°C) compared to the standard version.
- FLD** **Neutral air dehumidifier:** in addition to the base components, the unit is equipped with a partial air condenser, installed on the unit, designed to dissipate the extra heating load so that to ensure air neutral conditions in the ambient which has to be treated.

ACCESSORIES

- FARC** Air filter with frame for ducted installation.
- HYGR** Integrated mechanical hygrostat.
- HYGR** Remote mechanical hygrostat.
- HYGR** Remote mechanical hygrostat + thermostat.
- INOX** Stainless steel frame.
- PM** Available static pressure 200 Pa.
- TROL** Floor trolley version.

Models FL - FLD		FL-FLD560	FL-FLD560S	FL-FLD740	FL-FLD740S	FL-FLD940	FL-FLD940S
Moisture removed ⁽¹⁾	l/24h	564,1	564,1	736,7	736,7	937,3	937,3
Nominal input power ⁽¹⁾	kW	8,7	8,7	11,3	738,5	14,8	14,8
Max input power ⁽²⁾	kW	9,0	9,0	12,9	12,9	17,3	17,3
Nominal input current ⁽²⁾	A	19,3	19,3	25,0	25,0	31,3	31,3
Peak current	A	101,3	101,3	130,0	130,0	171,3	171,3
Air flow	m ³ /h	5150	5150	6850	6850	8200	8200
Available static pressure	Pa	50	50	50	50	50	50
Refrigerant		R407C	R407C	R407C	R407C	R407C	R407C
Sound pressure ⁽³⁾	dB(A)	72	72	73	73	74	74
Temperature operating range	°C	15-35	5-35	15-35	5-35	15-35	5-35
Humidity operating range	%	50-99	50-99	50-99	50-99	50-99	50-99
Power supply	V/Ph/Hz	400/3+N/50	400/3+N/50	400/3+N/50	400/3+N/50	400/3+N/50	400/3+N/50

Models FLZ		FLZ560	FLZ560S	FLZ740	FLZ740S	FLZ940	FLZ940S
Moisture removed ⁽¹⁾	l/24h	564,1	564,1	738,5	738,5	937,3	937,3
Input power ⁽¹⁾	kW	8,7	8,7	11,3	11,3	14,8	14,8
Cooling capacity ⁽⁴⁾	kW	21,3	21,3	28,5	28,5	40,6	40,6
Total power input ⁽⁴⁾	kW	9,1	9,1	11,7	11,7	15,3	15,3
Max power input ⁽⁵⁾	kW	10,2	10,2	14,5	14,5	18,7	18,7
Max input current ⁽⁵⁾	A	21,5	21,5	27,6	27,6	34,8	34,8
Peak current	A	103,5	103,5	132,6	132,6	174,8	174,8
Air flow	m ³ /h	5150	5150	6850	6850	8200	8200
Available static pressure	Pa	50	50	50	50	50	50
Refrigerant		R407C	R407C	R407C	R407C	R407C	R407C
Sound pressure ⁽³⁾	dB(A)	72	72	73	73	74	74
Temperature operating range	°C	15-35	5-35	15-35	5-35	15-35	5-35
Humidity operating range	%	50-99	50-99	50-99	50-99	50-99	50-99
Power supply	V/Ph/Hz	400/3+N/50	400/3+N/50	400/3+N/50	400/3+N/50	400/3+N/50	400/3+N/50

Performances refer to the following conditions:

(1) Room temperature 30°C; relative humidity 80%.

(2) Room temperature 35°C; relative humidity 80%.

(3) Sound pressure level measured at 1 mt from the unit in free field conditions according to ISO 9614.

(4) Room temperature 30°C; relative humidity 80%; ambient temperature 35°C.

(5) Room temperature 35°C; relative humidity 80%; ambient temperature 35°C.

FRAME

All FL units are made from hot-galvanised thick sheet metal, painted with polyurethane powder enamel at 180°C to ensure the best resistance against the atmospheric agents. The frame is self-supporting with removable panels. The drip tray is present standard in all FL units and it's in stainless steel. The colour of the units is RAL 7035.

REFRIGERANT CIRCUIT

The refrigerant gas used in these units is R407C. The refrigerant circuit is made by using international primary brands components and according to ISO 97/23 concerning welding procedures. The refrigerant circuit includes: sight glass, filter drier, thermal expansion valve with external equalizer, Schrader valves for maintenance and control, pressure safety device (according to PED regulation).

COMPRESSOR

The compressor is scroll type with crankcase heater and thermal overload protection by a klixon embedded in the motor winding. It's mounted on rubber vibration dampers and, by request, it can be supplied with some jackets to reduce the noise (accessory). The crankcase heater, when present, is always powered when the compressor is in stand-by. The inspection is possible through the frontal panel of the unit.

CONDENSER AND EVAPORATOR

The condensers and evaporators are made of copper pipes and aluminium fins. The diameter of the copper pipes is 3/8" and the thickness of the aluminium fins is 0,1 mm. The tubes are mechanically expanded into the aluminium fins to improve the heat exchange factor. The geometry of these condensers guarantees a low air side pressure drop and then the use of low rotation (and low noise emission) fans. All the units have a stainless steel drip tray. Besides this, each evaporator is supplied of a temperature probe used as automatic antifreeze probe.

FANS

The fan is centrifugal type. It's statically and dynamically balanced and supplied complete of the safety fan guard according to EN 294. It's mounted on the unit frame by interposition of rubber vibration dampers.

The electric motor is at 4 poles (about 1500 rpm). Connected to the fan by belts and pulleys and it's equipped of an integrated thermal overload protection. The protection class of the motors is IP 54.

AIR FILTER

It's supplied standard with the unit. It's made of filtering material in synthetic fibre without electrostatic charge. It can be removed for differential disposal, class G3, according to EN 779:2002.

MICROPROCESSOR

All units are supplied standard with microprocessor controls. The microprocessor controls the following functions: compressor timing, automatic defrost cycles, alarms. An appropriate LCD display shows the operation mode of the unit, set point and alarms.

ELECTRIC BOX

The electric switch board is made according to electromagnetic compatibility norms CEE 73/23 and 89/336. The accessibility to the board is possible after removing the front panel of the unit and the OFF positioning of the main switch. In all FL units are installed, standard, the compressors sequence relay which disables the operation of the compressor in case the power supply phase sequence is not the correct one (scroll compressors in fact, can be damaged if they rotate reverse wise). The following components are also standard installed: main switch, magnetic-thermal switches (as a protection of the fans), compressors fuses, control circuit automatic breakers, compressor contactors. The terminal board is also supplied with voltage free contacts for remote ON-OFF.

CONTROL AND PROTECTION DEVICES

All units are supplied with the following control and protection devices: defrost thermostat, which signals to the microprocessor control that a defrost cycle is needed and controls its termination, high pressure switch with manual reset, low pressure switch with automatic reset, high pressure safety valve, compressor thermal overload protection, fans thermal overload protection.

TEST

All the units are fully assembled and wired at the factory, carefully evacuated and dried after leak tests under pressure and then charged with refrigerant R407C. They are all fully operational tested before shipment. They all conform to European Directives and are individually marked with the CE label and provided with Conformity Declaration

REMOTE CONDENSER

The remote condensers are made of copper pipes and aluminium fins. The diameter of the copper pipes is 3/8" and the thickness of the aluminium fins is 0,1 mm. The tubes are mechanically expanded into the aluminium fins to improve the heat exchange factor. The geometry of these condensers guarantees a low air side pressure drop and then the use of low rotation (and low noise emission) fans. The fans are axial type with aluminium aerofoil blades complete of the safety fan guard. The protection class of the motors is IP 54. Furthermore the remote condenser is supplied of the low ambient condensing pressure control. This device controls the cooling circuit condensing pressure at different ambient temperatures, to keep it correct.

DESUPERHEATER (Only FLD versions)

The desuperheater is made of copper pipes and aluminium fins. The diameter of the copper pipes is 3/8" and the thickness of the aluminium fins is 0,1 mm. The tubes are mechanically expanded into the aluminium fins to improve the heat exchange factor. The fan of the desuperheater is axial type with aluminium aerofoil blades. It's statically and dynamically balanced and supplied complete of the safety fan guard according to EN 60335. It's mounted on the unit frame by interposition of rubber vibration dampers.

Versions FL - FLD - FLZ	Code	FL560	FL740	FL940	FLZ560	FLZ740	FLZ940
Integrated mechanical hygrostat	HYGR	○	○	○	-	-	-
Remote mechanical hygrostat	HYGR	○	○	○	-	-	-
Remote mechanical hygrostat + thermostat	HYGR	-	-	-	○	○	○
Available static pressure 200 Pa	PM	○	○	○	○	○	○
Floor trolley version	TROL	○	○	○	-	-	-
Stainless steel frame	INOX	○	○	○	○	○	○
Air filter with frame for ducted installation	FARC	○	○	○	○	○	○
Condensate discharge pump	POSC	○	○	○	○	○	○
Horizontal air discharge	HORI	○	○	○	○	○	○
Built in partial heat recovery version		-	-	-	-	-	-

Versions FL - FLD - FLZ	Code	FL560	FL740	FL940
Integrated mechanical hygrostat	HYGR	○	○	○
Remote mechanical hygrostat	HYGR	○	○	○
Remote mechanical hygrostat + thermostat	HYGR	-	-	-
Available static pressure 200 Pa	PM	○	○	○
Floor trolley version	TROL	○	○	○
Stainless steel frame	INOX	○	○	○
Air filter with frame for ducted installation	FARC	○	○	○
Condensate discharge pump	POSC	○	○	○
Horizontal air discharge	HORI	○	○	○
Built in partial heat recovery version		●	●	●

● Standard, ○ Optional, - Not available.

FL - FLZ

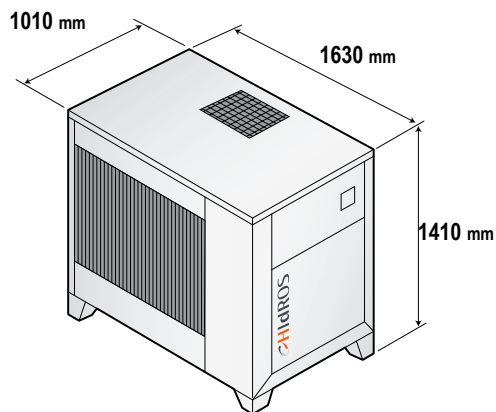

FLD

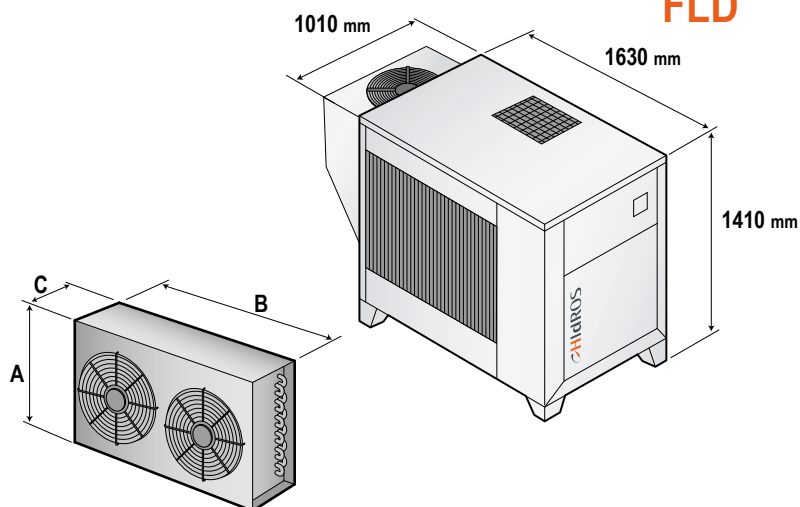

Mod.	FL-FLD (Kg)	FLZ (Kg)
560	390	390
740	412	412
940	439	439

Remote condenser (Only Z versions)

Mod.	A (mm)	B (mm)	C (mm)	Kg
560	555	1980	362	65
740	828	2015	428	65
940	828	2915	428	90